

Control Joint at floor line (2016)

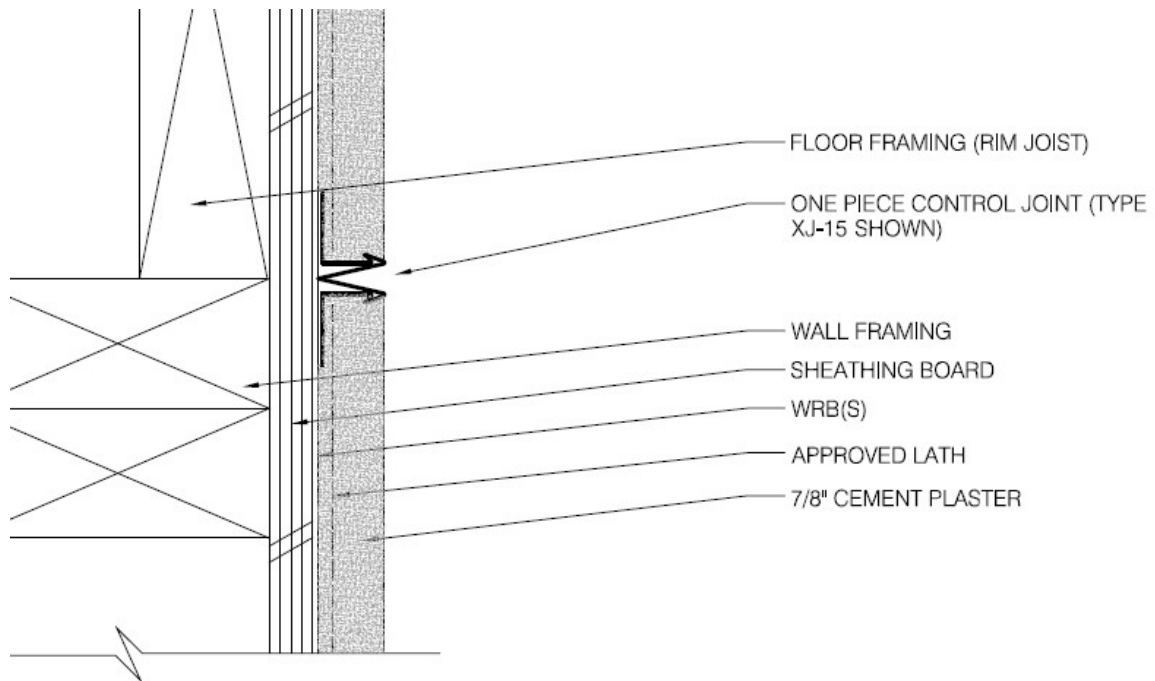

The single-piece control joint can accommodate small amounts of anticipated movement and stress, such as shrinkage of dimensional wood framing on low to mid-rise construction. Significant movement (greater than 1/4 inch) would necessitate a two-piece expansion joint. A second control joint may be placed at the top of rim joist.

- The Water-Resistant Barrier (WRB) must be continuous
- A backing of flashing paper or and Self Adhered Flashing (SAF) is optional but must be installed in a “Shingle-Fashion” with the WRB.
- Lath may be continuous behind joint with approval of building department
- Wood framing should be dry and reasonably straight with a moisture content below 19%
- Intersections, joints and terminations of the control joint should be sealed on walls exposed to wind-driven rains.

Downloading this detail is acknowledgement of reading and agreeing to the SMA detail “caveat page”.